

Specifications

| MODELS | SLC™-12 | | SLC™-18 | | SLC™-24 | |
|-------------------------------|---------|-------------|---------|-------------|---------|-------------|
| MEASUREMENTS | Metric | US | Metric | US | Metric | US |
| Working height: | | | | | | |
| standard forks - forks up | 3.94 m | 12 ft 11 in | 5.64 m | 18 ft 6 in | 7.32 m | 24 ft |
| standard forks - forks down | 3.40 m | 11 ft 2 in | 5.10 m | 16 ft 9 in | 6.78 m | 22 ft 3 in |
| adjustable forks - forks up | 3.94 m | 12 ft 11 in | 5.64 m | 18 ft 6 in | 7.32 m | 24 ft |
| adjustable forks - forks down | 3.40 m | 11 ft 2 in | 5.10 m | 16 ft 9 in | 6.78 m | 22 ft 3 in |
| boom** | 3.70 m | 12 ft 2 in | 5.41 m | 17 ft 9 in | 7.10 m | 23 ft 3 in |
| A Height - stowed | 2.18 m | 7 ft 2 in | 2.18 m | 7 ft 2 in | 2.18 m | 7 ft 2 in |
| B Length - stowed | 86 cm | 2 ft 10 in | 86 cm | 2 ft 10 in | 86 cm | 2 ft 10 in |
| C - operating | 1.60 m | 5 ft 3 in | 1.85 m | 6 ft 1 in | 2.06 m | 6 ft 9 in |
| D Width - stowed* | 80 cm | 2 ft 7.5 in | 80 cm | 2 ft 7.5 in | 80 cm | 2 ft 7.5 in |
| - with stabilisers lowered | 1.68 m | 5 ft 6 in | 1.68 m | 5 ft 6 in | 1.68 m | 5 ft 6 in |

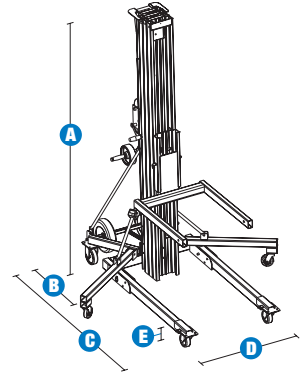

| PRODUCTIVITY | | | | | | |
|--------------------------------|--------|---------|--------|---------|--------|---------|
| Load capacity: | | | | | | |
| 36 cm (1 ft 2 in) load centre | 295 kg | 650 lbs | 295 kg | 650 lbs | 295 kg | 650 lbs |
| 61 cm (2 ft) load centre | 193 kg | 425 lbs | 193 kg | 425 lbs | 193 kg | 425 lbs |
| 1.07 m (3 ft 6 in) load centre | 82 kg | 180 lbs | 73 kg | 160 lbs | 73 kg | 160 lbs |
| D Ground clearance | 5 cm | 2 in | 5 cm | 2 in | 5 cm | 2 in |
| Load height minimum | 15 cm | 6 in | 15 cm | 6 in | 15 cm | 6 in |

| POWER | | | | | | |
|------------------------|---------------|---------------|---------------|---------------|---------------|---------------|
| Average cranks: | | | | | | |
| standard winch | 27.8 cranks/m | 8.5 cranks/ft | 27.8 cranks/m | 8.5 cranks/ft | 27.8 cranks/m | 8.5 cranks/ft |
| two speed winch, high | 13.1 cranks/m | 4 cranks/ft | 13.1 cranks/m | 4 cranks/ft | 13.1 cranks/m | 4 cranks/ft |
| two speed winch, low | 49.2 cranks/m | 15 cranks/ft | 49.2 cranks/m | 15 cranks/ft | 49.2 cranks/m | 15 cranks/ft |

| WEIGHT | | | | | | |
|--------|--------|---------|--------|---------|--------|---------|
| | 102 kg | 225 lbs | 139 kg | 307 lbs | 157 kg | 347 lbs |

| LOAD HANDLING ATTACHMENTS | | | | | | |
|--|----------------|-------------------|----|--|-----------------|-------------|
| MEASUREMENTS | Metric | | US | | Weight - Metric | Weight - US |
| Standard forks (l/w/d)*** | 71/58/6 cm | 28/23/2.5 in | | | 12 kg | 26.5 lbs. |
| Adjustable forks (l/w/d)*** | 70/28-76/6 cm | 27.5/11-30/2.5 in | | | 24 kg | 52.5 lbs. |
| Fork extensions detached (each) (l/w/d)*** | 76/5/8 cm | 30/2/3 in | | | 2 kg | 4.5 lbs |
| Fork extensions attached (each) (l/w/d)*** | 64/5/8 cm | 25/2/3 in | | | 2 kg | 4.5 lbs |
| Boom (l/w/d)*** | 46-107/4/15 cm | 18-42/1.5/6 in | | | 18 kg | 39.9 lbs |
| Pipe cradle (l/w/d)***/* | 70/61/15 cm | 27.5/24/6 in | | | 4.5 kg | 10 lbs |
| Load platform (l/w/d)*** | 67/58/6 cm | 26.3/23/2.5 in | | | 14 kg | 31.5 lbs |

* Outside dimensions.
** Measured from ground to bottom of shackle.
*** Length/Width/Depth.
**** Handles round objects up to 76 cm (30 in) in diameter.

Features

EASILY CONFIGURED TO MEET YOUR NEEDS

PLATFORM OPTIONS

- Boom
- Standard forks
- Adjustable forks
- Fork extensions
- Pipe cradle
- Load platform

POWER OPTIONS

- One speed winch
- Two speed winch

BASE OPTIONS

- Standard base
- Stabiliser set

CASTER & BRAKE OPTIONS

- 10 cm (4 in) front casters
- 13 cm (5 in) rear casters with side brakes
- Fixed front caster option
- Mast brake (standard)

STANDARD FEATURES

MEASUREMENTS

SLC™-12

- 3.94 m (12 ft 11 in) working height
- Up to 295 kg (650 lb) lift capacity

SLC™-18

- 5.64 m (18 ft 6 in) working height
- Up to 295 kg (650 lb) lift capacity

SLC™-24

- 7.32 m (24 ft) working height
- Up to 295 kg (650 lb) lift capacity

PRODUCTIVITY

- Standard forks
- Heavy-duty design
- Strong, lightweight aluminium telescoping mast
- Single door access
- Quick set up requires no tools
- Interchangeable load handling attachments

STANDARD FEATURES cont.

PRODUCTIVITY cont.

- Non-marking 10 cm (4 in) front casters and 13 cm (5 in) rear casters with side brakes
- Rear transport wheel assembly
- Glide rails allow easy loading and unloading, on or off a vehicle, for transport
- Hold-down bar secures mast assembly during transport
- Captive stabiliser set (standard on SLC™-18, -24)

POWER

- One speed winch



OPTIONS & ACCESSORIES

PRODUCTIVITY

- Boom
- Adjustable forks
- Fork extensions
- Pipe cradle
- Load platform
- Fixed front casters
- Stabiliser set (option on SLC™-12)

POWER

- Two speed winch

European Offices

UK

The Maltings
Wharf Road
Grantham NG31 6BH
UK
Tel: +44 (0)1476 584333
Fax: +44 (0)1476 584334

France

10, ZA de la Croix St. Mathieu
28320 Gallardon
France
Tel: +33 (0)2 37 26 09 99
Fax: +33 (0)2 37 26 09 98

Germany

Finienweg 3
28832 Achim/Bremen
Germany
Tel: +49 (0)4202 8852-0
Fax: +49 (0)4202 8852-25

Spain

Gaià 31, Pol. Ind. Plà d'en Coll
08110 Montcada i Reixac
Barcelona
Spain
Tel: +34 93 572 50 90
Fax: +34 93 572 50 91

Scandinavia

Tagenevägen 72
425 37 Hisings Kärra
Sweden
Tel: +46 31 57 51 00
Fax: +46 31 57 90 20

Genie United States

18340 NE 76th Street
P.O. Box 97030
Redmond, Washington 98073-9730
USA
Tel: +1 425 881-1800
Fax: +1 425 883-3475

WEB: www.genieindustries.com
Email: infoeurope@genieind.com

Distributed By: