

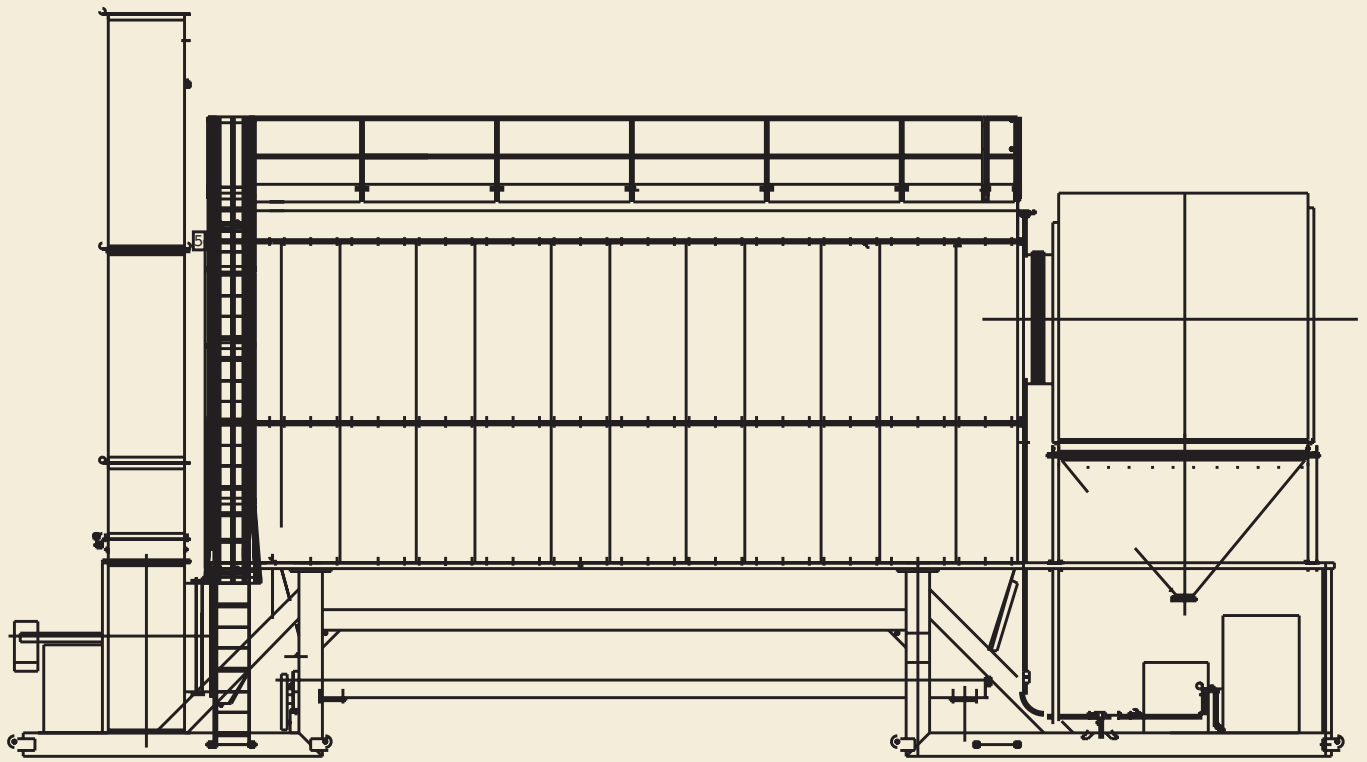

TEREX

Relocatable Bag House | SPECIFICATIONS



BH40R
RELOCATABLE BAG HOUSE

ROADBUILDING

BH40R RELOCATABLE BAG HOUSE

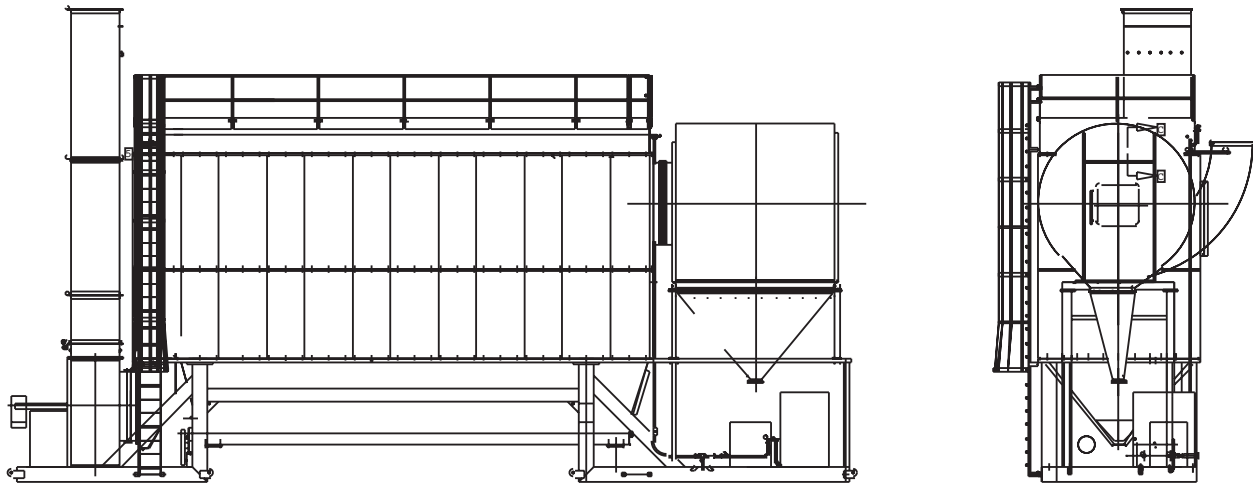

Large filtration area with high air volume: High filtration efficiency: 640 bags with total cloth area measuring 15,200 ft² (1412 m²), 76,000 ACFM, 5.0:1 A/C ratio with 300 hp #58 exhaust fan

Strong, welded construction: Housing, hopper and clean air plenum manufactured of all-welded construction using $\frac{3}{16}$ in (4.76 mm) mild steel. Housing constructed by alternating U-shaped steel plates creating 3 in (76 mm) x 5 in (127 mm) tubular stiffeners which are integral to the house construction. Interior surfaces of clean air plenum painted with one coat of high-temperature paint.

Tube sheet for mounting filter bags and support cages constructed of 7 ga (4.55 mm) drawn quality steel plate. 16 bags per row, number of rows same as unit size; rows located on $9\frac{1}{4}$ in (234 mm) centers, bags located on $7\frac{3}{4}$ in (196 mm) centers within a row.

High-efficiency bag cleaning: Filter bag cleaning is accomplished by directing a burst of compressed air to each row of bags through a double-diaphragm valve and blowpipe with a drilled hole above each bag. All solenoids are factory wired to a terminal box.

Better fines removal: Collector fines continuously removed from hopper by factory-installed 12 in (304 mm) diameter screw conveyor driven by a 7.5 hp (5.6 kW) motor through a shaft-mounted reducer. Screw conveyor equipped with wire mesh protective screen.

Complete structural assembly: With tubular steel supports: caged ladder for access to top of unit; handrails factory-installed, hinged down for shipment.

EPA emission standards compliant: BH40R baghouse provides fabric filter emission control of the highest quality and is easily capable of conforming to particulate emission requirements of the United States Environmental Protection Agency standards for Hot-Mix Asphalt Plants.

Important Note: All electrical specifications used herein refer to U. S. Standards of voltage and frequency. Any electrical equipment that is factory installed will be compatible with power availability requirements of any customer's country.

Features

Bags and Cages

- Each bag is $6\frac{1}{4}$ in (157 mm) diameter, with 23.75 ft² (2.20 m²) cloth area, 14 oz./yd² bags, and maximum operating temperature of 375°F (190°C)
- Cages are 5.85 in (148 mm) diameter. Snap-in bag system.

Exhaust Fan

- Exhaust fan 300 hp #58
- Heavy, industrial-duty centrifugal fan with backward-inclined blades operates more efficiently and requires less horsepower than conventional radial-bladed designs.
- Automatically controlled opposed blade outlet damper and actuator assembly operated through draft sensing at the burner to maintain proportional air volume for optimum plant operation and fuel use efficiency.
- Two 150 hp motors, sheaves, belts and belt guard.

Skimmer

Primary dust collection is accomplished by a frame-mounted fully-lined horizontal cyclonic-type primary collector with hopper.

Ductwork

Outlet ductwork from outlet flange of baghouse to fan/damper assembly and exhaust stack with testing ports and a test platform. Inlet duct from drum mixer breaching to baghouse.

Compressor

460V/3ph/60 Hz, 50 hp, screw-type compressor with cabinet enclosure, air -cooled with air-cooled after-cooler, hour meter, full voltage starter, heavy-duty air cleaner and remote start/stop contacts sized to supply all air requirements for the drum-mixer plant.

Collector Fines Removal and Return System

Fines discharging from the baghouse are conveyed directly back to the drum dust injection screw by two 12 in diameter screw conveyors each driven by a 7.5 hp (5.6 kW) motor.

Options

- 250 hp Fan drive
- 16 oz bags
- Variable frequency fan drive